

# TEKSENS

## TCFS-410 Series Flow Switch

### PRODUCT DATA



### Features

- No moving parts and free maintenance;
- Easy to install, one model is suitable for various pipe diameter requirements;
- The switching value is continuously adjusted, and the pressure loss is extremely low;
- Compact structure, LED display flow trend and switching status.

### Principle

Based on the thermal principle, the closed probe contains two resistors, one of which is heated as a detection resistor, and the other is not heated as a reference resistor. When there is a medium flowing, the heat received by the thermal sensor will follow the medium. When the flow rate changes, the thermal sensor converts the temperature difference signal into an electrical signal. When the flow rate reaches a certain set point, the thermal flow switch outputs a switching signal.

### Application

The flow switch is mainly installed on-line or plug-in in pipelines such as water, gas and oil to monitor the flow in the system. When the flow is higher or lower than a certain set point, the output alarm signal is triggered and transmitted to the system. After the system obtains the signal, the corresponding instruction action can be made to avoid or reduce the “dry burning” of the main engine.

It can be widely used in:

- Industrial automation
- Mechanical equipment
- Air compression industry
- Refrigeration and air conditioning fields

In industrial occasions, it is specifically used in water-cooled welding machines, laser equipment cooling systems, vacuum coating machines, electric furnaces, polysilicon ingot furnaces, etc.

## Specification

Measurement range:

1~150cm/s (water)

3~300cm/s (oil)

20~2000cm/s (air)

Output signal: PNP, NPN, Relay

Power supply:

24V±20%DC

Max. 400mA for PNP or NPN

Max. 1A@36VAC/DC relay type

No-load current: Max. 80mA

Set type: Potentiometer setting

Rated pressure: 100bar

Medium temperature changes: ≤4°C/s

Response time: 1~13s

Initialization time: 8s

Electrical protection: Reverse, short circuit,  
overload protection

Protection: IP65

Medium temperature: -20~90°C

Ambient temperature: -20~80°C

Material:

Probe: SS304/SS316

Housing: Stainless Steel/Cast Aluminum

Accuracy: ±2%

## Dimension

Standard type

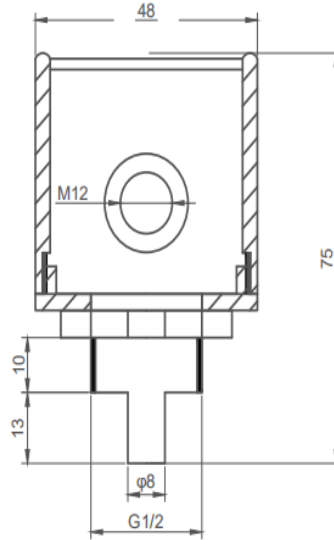

Ex-proof type

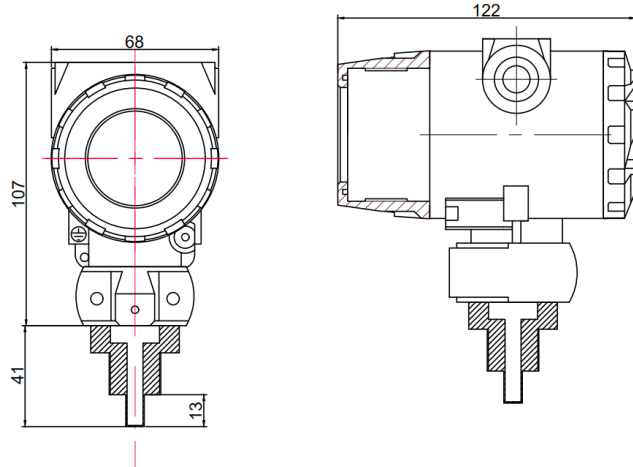

## Wiring type

Standard type

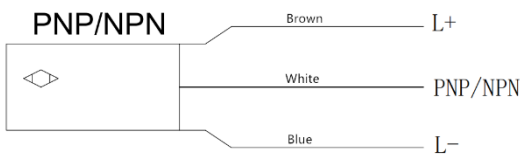
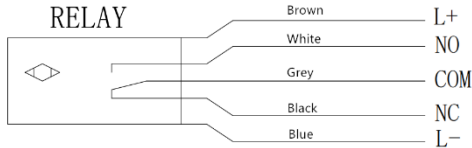

Ex-proof type

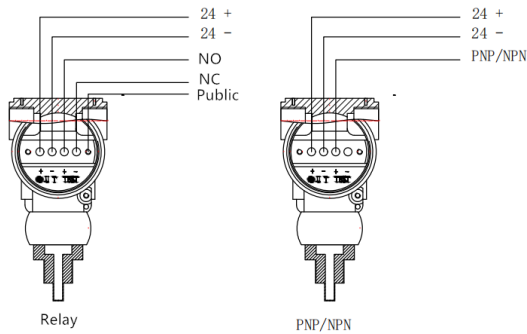

## Selection

TFCS-410 series					
A	Insertion type		Type		
B	Display type				
F	Ex-proof type				
	G12	G1/2" (Insertion type)		Process connection	
	G14	G1/4" (Insertion type)			
	H1	External thread (Pipe type)			
	H2	Flange (Pipe type)			
	Z	Customized			
	G	24V±20%DC		Power supply	
		1	PNP		Output signal
		2	NPN		
		3	Relay (NO/NC)		
		S1	SS304		Wetted material
		S2	SS316		



Red LED on:  
Cutout or flow rate below setpoint switch release



Yellow LED on:  
The flow rate is equal to the setpoint switch action.



Yellow and green LED on:  
The flow rate is larger than the set value, and the more the green light turns on, the greater the flow rate.