

Product introduction

Description

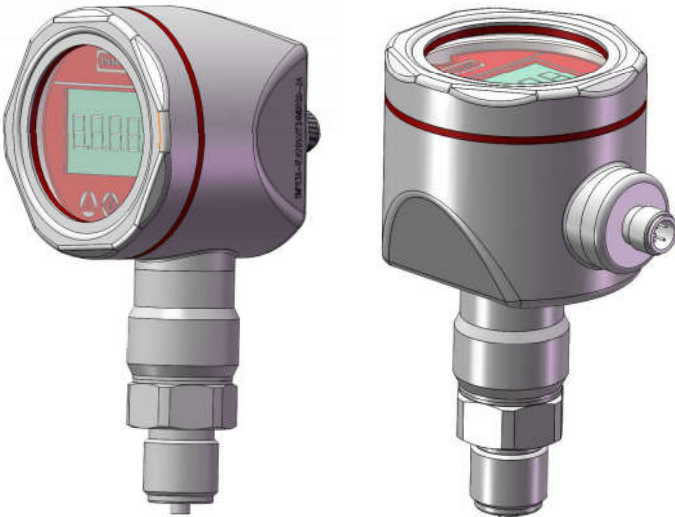

**Industrial pressure transmitter**

The new microprocessor and surface mount technology transmission module which collect and process the signal of pressure sensor and amend the measurement error through built-in temperature sensor, fully improved the performance of pressure transmitter.

The new external three-button menufunction designs make it easier to operate the parameter settings and safer to operate in dangerous situations. The HART manual controller or the HART software can realize measurement information configuration remotely.

Main parameters

Pressure types	Gauge pressure
Measuring range	5kPa-100MPa, please refer to the ordering information chapter
Output signal	4-20mA,4-20mA+HART ,customer
Reference accuracy	0.2% URL, 0.5% URL, optional 0.1%URL

Field of application

Pressure, level

Approvals

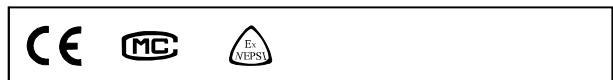

Measuring medium

Liquid, gas, or steam flow as well as liquid level, density and pressure

Technical Specifications

Measuring range and limit

Nominal value	Smallest calibratable span	Lower range limit ( LRL )	Upper range limit ( URL )	Overload limit
7kPa	5kPa	-7kPa	7kPa	10.5kPa
20kPa	10kPa	-20kPa	20kPa	30kPa
35kPa	20kPa	-35kPa	35kPa	52.5kPa
100kPa	35kPa	-100kPa	100kPa	150kPa
200kPa	100kPa	-100kPa	200kPa	300kPa
700kPa	200kPa	-100kPa	700kPa	1050kPa
1MPa	500kPa	-0.1MPa	1MPa	1.5MPa
1.7MPa	1MPa	-0.1MPa	1.7MPa	2.55MPa
3.5MPa	1.7MPa	-0.1MPa	3.5MPa	5.25MPa
7MPa	3.5MPa	-0.1MPa	7MPa	10.5MPa
17MPa	7MPa	-0.1MPa	17MPa	25.5MPa
35MPa	17MPa	-0.1MPa	35MPa	52.5MPa
40MPa	20MPa	-0.1MPa	40MPa	60MPa
60MPa	30MPa	-0.1MPa	60MPa	90MPa
70MPa	35MPa	-0.1MPa	70MPa	105MPa
100MPa	50MPa	-0.1MPa	100MPa	150MPa

The unit of the measuring range above can be converted into kg/cm<sup>2</sup>、MPa and kPa, etc. Provide other measuring range according to requirements. Adjust requirements: lower range value (LRV) and upper range value (URV) can be adjusted within the scope of the upper and lower range limit, smallest calibratable span ≤ | URV - LRV | ≤ URL

Reference accuracy

Standard and reference conditions, including linearity(BFSL), hysteresis and repeatability. calibration temperature: 20 °C ± 5 °C			
Linear output accuracy	Typical	±0.2%URL	Nominal value : 7kPa、20kPa、35kPa、100kPa、200kPa、700kPa、1MPa、1.7MPa、3.5MPa、7MPa、17MPa、35MPa、40MPa、60MPa、70MPa、100MPa
	Max	±0.5% URL	

The accuracy of square root output is 1.5 times of above linear reference output accuracy.

Standard specifications and reference conditions

Test standard: GB/T28474 / IEC60770; Zero based-calibration span, Silicon oil filling, 316L stainless steel isolation diaphragm, 4-20mA analog output.

Power supply effects

Zero and span change should not be more than ± 0.005% URL/V when power supply changes in 10.5/16.5-55VDC

Performance specifications

The overall performance including but not limited to 【 reference accuracy 】 , 【 environment temperature effects 】 and other comprehensive error

Typical accuracy: ±0.2%URL

Stability: ±0.1% URL/ year

Mounting position effects

Apply to any position. Install error less than 400Pa can be corrected by PV=0 reset.

Technical Specifications

Vibration effects

According to GB/T 1827.3/IEC61298-3 tests, <0.1% URL

Output signal

4-20mA two wire. Customers can choose linear output or square root output. Digital process variables superimpose on 4-20mA signal and apply to any hosts with HART protocol.

Ambient temperature effects(Typical)

Total impact Within the range of -20-80 °C	±(0.1+0.1TD)% URL
--	-------------------

Insulation resistance

≥ 20M Ω@, 100VDC

Damping time

Total damping time constant: equal to the sum of damping time of amplifier and sensor capsule

Damping time of amplifier : 0-100S adjustable

Diaphragm capsule (isolation sensor diaphragm and silicon oil filling) damping time: ≤0.2s

Startup after power off : ≤6S

Normal services after data recovery : ≤31S

Weight

Net weight: about 0.65 kg ( without mounting bracket and process connection adaptor )

Environment condition

Items	Operational condition
Working temperature	-40-85°C, integrated LCD display: -20-70°C
Storage temperature	-40-110°C, integrated LCD display: -40-85°C
Media temperature	Silicon oil filling: -40-120°C
Working humidity	5-100% RH@40°C
Protection class	IP67

Power supply

Item	Operating conditions
Standard/flame proof	10.5-55VDC
HART protocol	16.5-55VDC, Communication load resistance 250Ω
Load resistance	0-2119 Ω for working condition, 250-600Ω for HART protocol
Transmission distance	<1000m
Power consumption	≤500mW@24VDC , 20.8mA

Power supply and load requirements

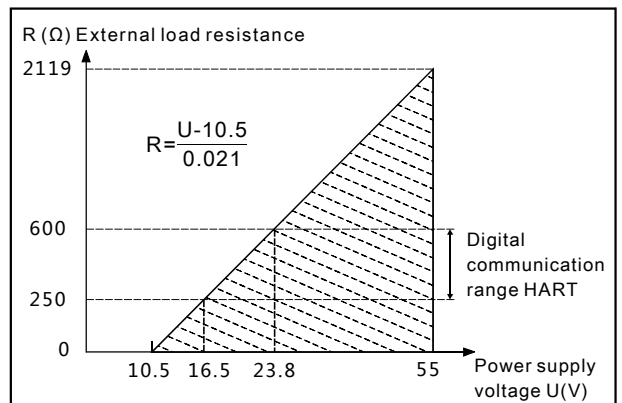

## Technical Specifications

### EMC environment

NO.	Test items	Basic standards	Test conditions	Performance level
1	Radiated interference	GB/T 9254/CISPR22	30MHz-1000MHz	OK
2	Conducted interference (DC power port)	GB/T 9254/CISPR22	0.15MHz-30MHz	OK
3	Electrostatic discharge immunity test (ESD)	GB/T 17626.2/IEC61000-4-2	4kV(Contact ),8kV(Air)	B(Note2)
4	Immunity to radio frequency EM-fields	GB/T 17626.3/IEC61000-4-3	10V/m(80MHz-1GHz)	A(Note1)
5	Power frequency magnetic field Immunity test	GB/T 17626.8/IEC61000-4-8	30A/m	A(Note1)
6	Electrical fast transient / Burst Immunity Test	GB/T 17626.4/IEC61000-4-4	2kV(5/50ns,100kHz)	B(Note2)
7	Surge immunity requirements	GB/T 17626.5/IEC61000-4-5	1kV(Line to line) 2kV(Line to ground) (1.2us/50us)	B(Note2)
8	Immunity to conducted disturbances induced by radio frequency fields	GB/T 17626.6/IEC61000-4-6	3V(150kHz-80MHz)	A(Note1)

(Note 1) Performance level A: The performance within the limits of normal technical specifications.

(Note 2) Performance level B: Temporary reduction or loss of functionality or performance, it can restore itself. The actual operating conditions, storage and data will not be changed.

**Menu function**

**Transmission module type**

Output signal	Local control	Remote control
4-20mA+HART	LCD/3 buttons on body	HART
4-20mA	LCD/3 buttons on body	-

**LCD display unit**

Display mode	Details
PV	Process variable shows on main screen, percentage and progress bar shows on secondary screen
mA	Current shows on main screen, percentage and progress bar shows on secondary screen
%	Percentage shows on main screen, percentage and progress bar shows on secondary screen

**Unit**

Unit	Definition
kPa	Kilopascal
MPa	Megapascals
bar	Bar
psi	Pounds per square inch
mmHg	Millimetre(s) of mercury@0°C
mmH2O	Millimeter of water@4°C
mH2O	Meter of water@4°C
inH2O	Inches of water@4°C
ftH2O	Feet of water@4°C
inHg	Inches of mercury@0°C
mHg	Meter mercury column@0°C
TORR	Torr
mbar	Millibar
g/cm2	Gram per square centimeter
kg/cm2	Kilogram per square centimeter
Pa	PA
ATM	Standard atmospheric pressure
mm	Millimeter(Note1)
m	Meter(Note1)

Note1: length unit need mark medium density

**Measuring menu set**

Mark	State
URV	Upper range value
LRV	Lower range value

**Damping time**

Units	Setting range
S	0-100

**Analog output type**

Parameters	Output type
mA LINER	Linearity
mA <input checked="" type="checkbox"/>	Square root

**Alarm signal**

Parameters	Alarm signal
ALARM NO	None
ALARM H	20.8mA
ALARM L	3.8mA

**Fix output**

Parameters	Fix output value
FIX/C NO	None
3.8000	3.8000mA
4.0000	4.0000mA
8.0000	8.0000mA
12.000	12.000mA
16.000	16.000mA
20.000	20.000mA
20.800	20.800mA

**Quick menu**

Parameter	Instruction
PV=0	Set current output to zero value, used to correct the error caused by static pressure and installation.
Zero adjustment	4mA re-range with pressure
Span adjustment	20mA re-range with pressure
Restore factory setting	Restore backup data when error

Product selection instruction

Sensor select instruction

Code	Nominal value	Description
L702G	7kPa	Range -7-7kPa, smallest calibratable span 5kPa
L203G	20kPa	Range -20-20kPa, smallest calibratable span 10kPa
L353G	35kPa	Range -35-35kPa, smallest calibratable span 20kPa
L104G	100kPa	Range -100-100kPa, smallest calibratable span 35kPa
L204G	200kPa	Range -100-200kPa, smallest calibratable span 100kPa
L704G	700kPa	Range -100-700kPa, smallest calibratable span 200kPa
L105G	1MPa	Range -0.1-1MPa, smallest calibratable span 500kPa
L175G	1.7MPa	Range -0.1-1.7MPa, smallest calibratable span 1MPa
L355G	3.5MPa	Range -0.1-3.5MPa, smallest calibratable span 1.7MPa
L705S	7MPa	Range -0.1-7MPa, smallest calibratable span 3.5MPa
L176S	17MPa	Range -0.1-17MPa, smallest calibratable span 7MPa
L356S	35MPa	Range -0.1-35MPa, smallest calibratable span 17MPa
L406S	40MPa	Range -0.1-40MPa, smallest calibratable span 20MPa
L606S	60MPa	Range -0.1-60MPa, smallest calibratable span 30MPa
L706S	70MPa	Range -0.1-70MPa, smallest calibratable span 35MPa
L107S	100MPa	Range -0.1-100MPa, smallest calibratable span 50MPa

Adjust requirements: lower range value (LRV) and upper range value (URV) can be adjusted within the scope of the upper and lower range limit, smallest calibratable span  $\leq |URV - LRV| \leq URL$

Code	Parts	Description
S	Sensor seal	O-ring, FKM ( high temperature condition)
F		Stainless steel welding seal
C		O-ring, neoprene ( low temperature condition)

Seal ( S/C )

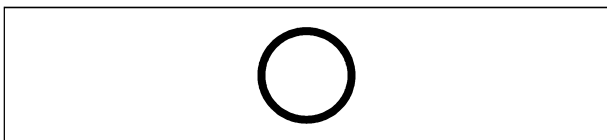

Electrical connection

Code	Item	Description
F1	Electrical connection	Stainless steel terminal, aviation plug M12*1 (4 pin) (H2), IP67, vertical mounting
F2		Stainless steel terminal, aviation plug M12*1 (4 pin) (H2), IP67, horizontal mounting

Housing(F1)

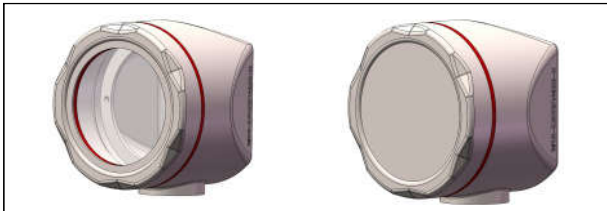

Housing(F2)



Product selection instruction

Aviation plug, M12\*1, 4 pin(H2)



Aviation plug, M12\*1, 4 pin(H2)

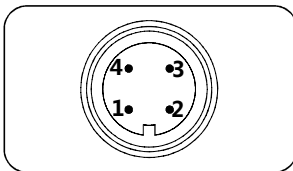

Label	Two wires
1	Power+
2	
3	Key-z
4	Power-

Electrical connection accessories

Aviation plug straighter(J1)

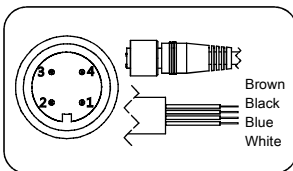

Label	Two wires
1/Brown	Power+
2/White	
3/Blue	Key-z
4/Black	Power-

Aviation plug elbow (J2)

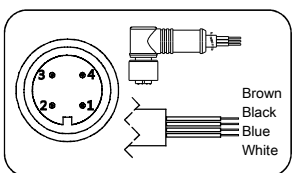

Label	Two wires
1/Brown	Power+
2/White	
3/Blue	Key-z
4/Black	Power-

Transmission module

Code	Items	Description
F	Output signal	4-20mA two wire, power supply: 10.5-55VDC
H		4-20mA+HART two wire, power supply: 16.5-55VDC
A	Display	Without display
C		With LCD display

Display module ( C )



Wetted parts

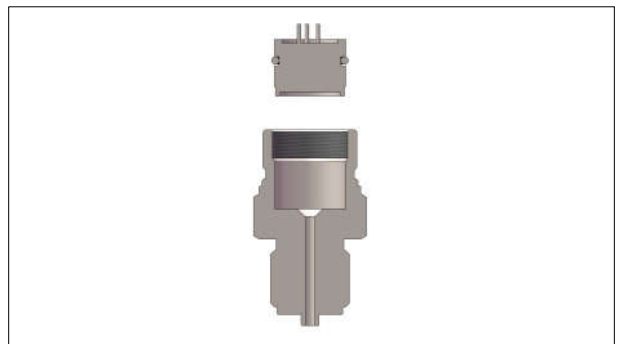

Process connection select instruction

Code	Items	Description
4	Material	Stainless steel, SUS304
6		Stainless steel, SUS316
M01	Specifications	M20*1.5(M), Φ3 pressure lead hole, GB/T193-2003, ISO261
G01		G1/2(M), Φ3 pressure lead hole, EN837
G02		G1/4(M), Φ3 pressure lead hole, EN837
G08		G1/4(M), Φ3 pressure lead hole, GB/T7307, ISO228, DIN16288, BS2779, seal reference DIN3852-E (back-end seal) Max measuring 60MPa
R01		1/2-14NPT(M), Φ3 pressure lead hole, GB/T12716, ANSI/ASME B1.20.1
R02		1/4-18NPT(M), Φ3 pressure lead hole, GB/T12716, ANSI/ASME B1.20.1
R03		1/2-14NPT(F), Φ3 pressure lead hole, GB/T12716, ANSI/ASME B1.20.1
R04		1/4-18NPT(F), Φ3 pressure lead hole, GB/T12716, ANSI/ASME B1.20.1

Product drawing and dimension

Drawing and dimension with display(C)/without display(A) (horizontal mounting) ( unit:mm)

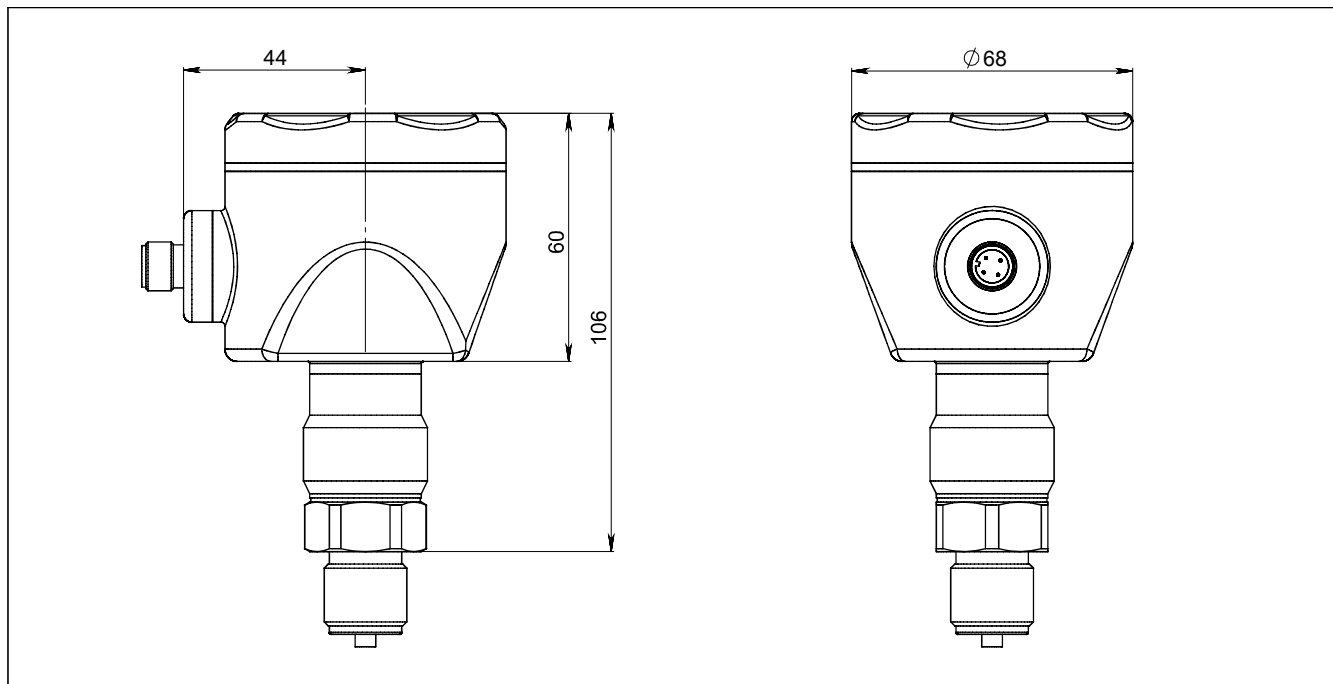

Drawing and dimension with display(C)/without display(A) (vertical mounting) ( unit:mm)

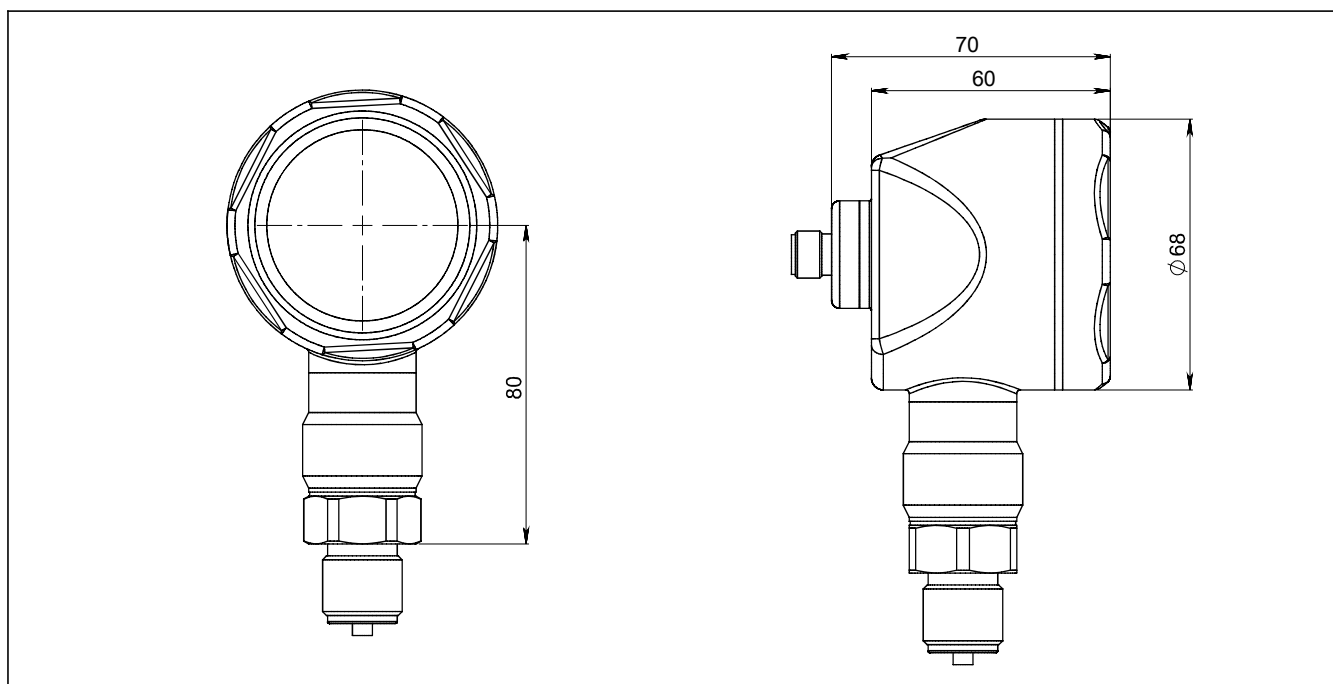



Product drawing and dimension

Process connection(M01) (unit: mm)

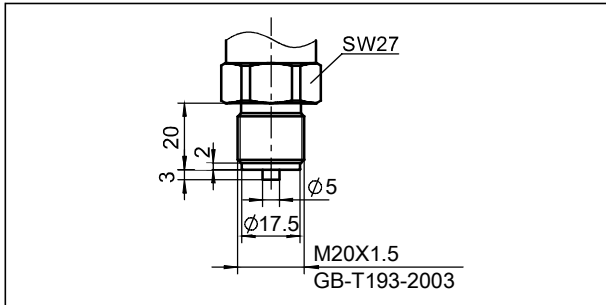

Process connection(G01) (unit: mm)

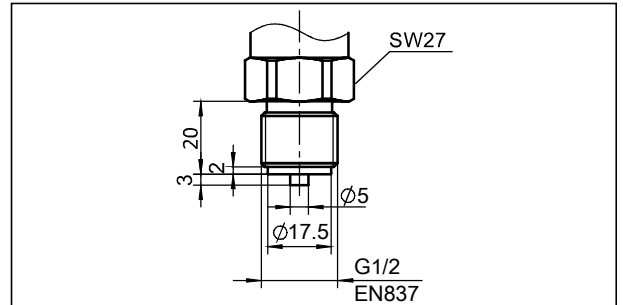

Process connection(G02) (unit: mm)

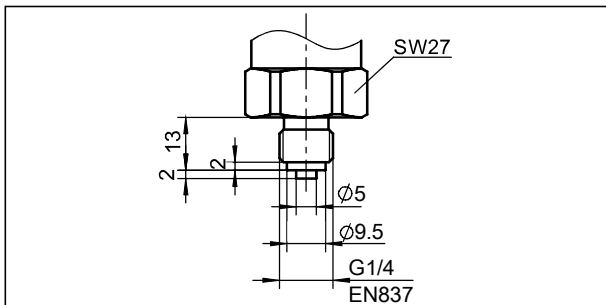

Process connection(G08) (unit: mm)

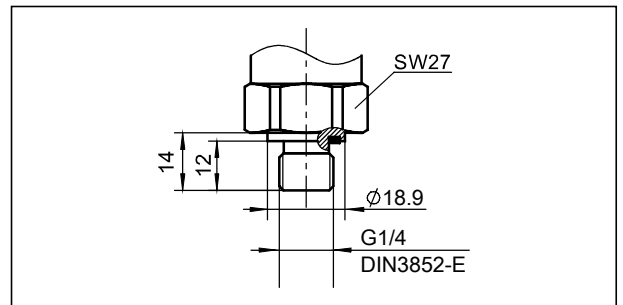

Process connection(R01) (unit: mm)

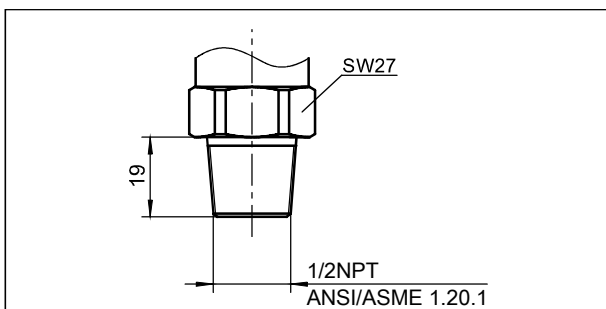

Process connection(R02) (unit: mm)

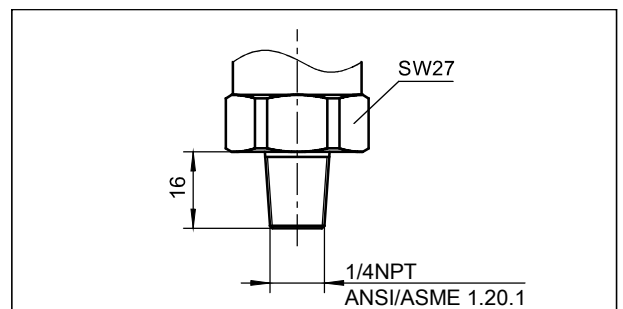

Process connection(R03) (unit: mm)

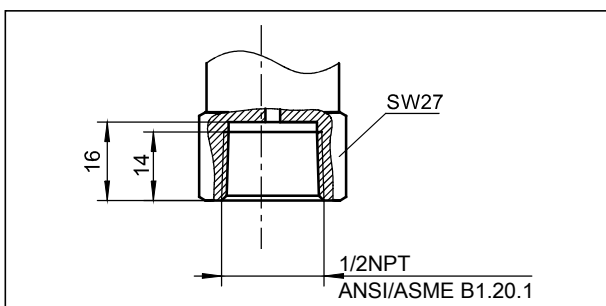

Process connection(R04) (unit: mm)

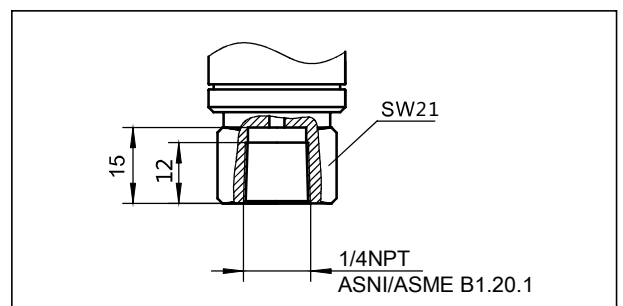

Disclaimer: all the data used in the product description is not legally binding. Relevant technical details may be changed due to further improve

Product drawing and dimension

Heat exchange connector(N1) (unit: mm)

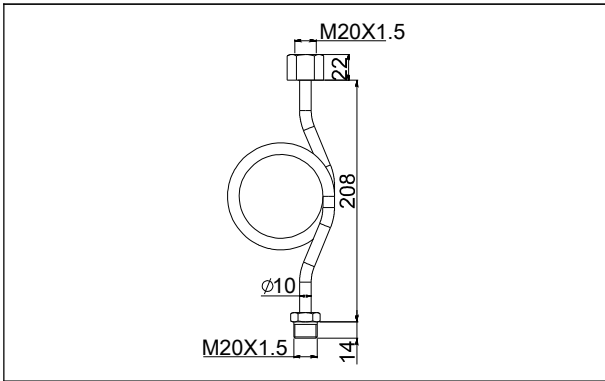

Heat exchange connector(N2)(unit: mm)

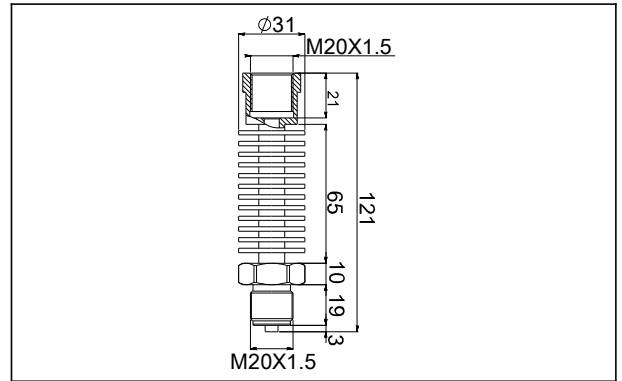

Welding adaptor(Z1) (unit: mm)

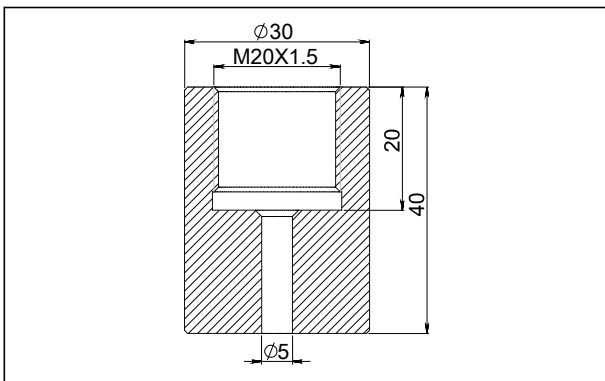

Welding adaptor(Z2) (unit: mm)

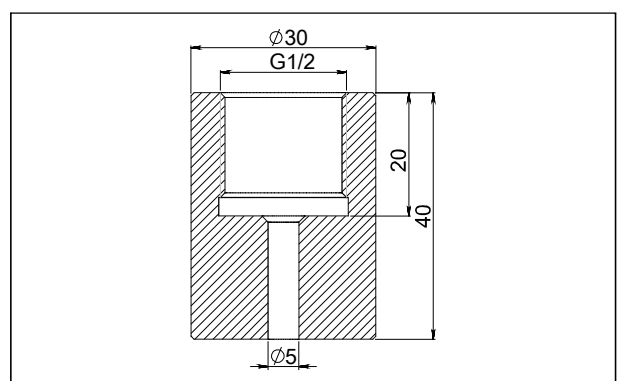

Aviation female plug straighter(J1) (unit: mm)

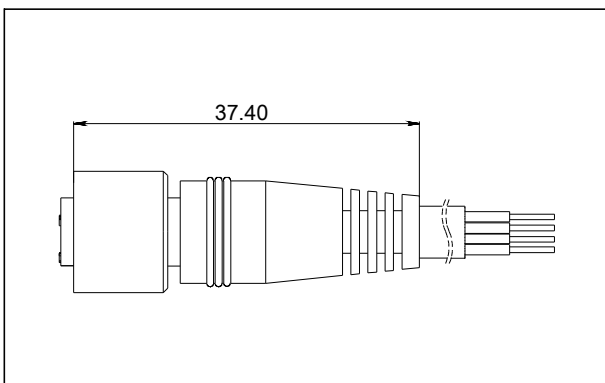

Aviation female plug elbow(J2) (unit: mm)

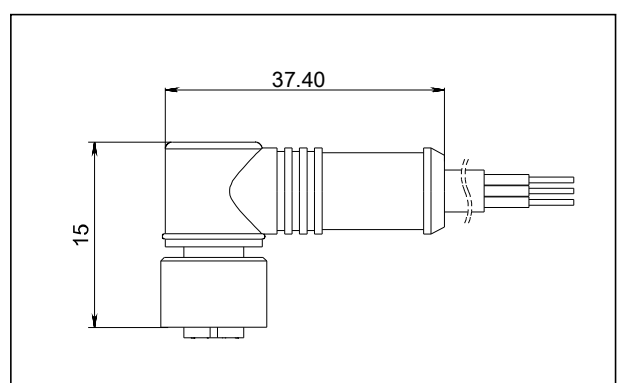

**Ordering information chapter**

Item	Parameters	Code	Instruction	(*) fast delivery available
	Model	DMP305X-TLF	Piezoresistive silicon gauge pressure sensor	
Sensor	Separator	-	Detailed specifications as following	
	Pressure range code	L702G	Nominal value(URL): 7kPa	
		L203G	Nominal value(URL): 20kPa	
		L353G	Nominal value(URL): 35kPa	*
		L104G	Nominal value(URL): 100kPa	*
		L204G	Nominal value(URL): 200kPa	*
		L704G	Nominal value(URL): 700kPa	*
		L105G	Nominal value(URL): 1000kPa	*
		L175G	Nominal value(URL): 1700kPa	*
		L355G	Nominal value(URL): 3.5MPa	*
		L705S	Nominal value(URL): 7MPa	*
		L176S	Nominal value(URL): 17MPa	
		L356S	Nominal value(URL): 35MPa	
		L406S	Nominal value(URL): 40MPa	
		L606S	Nominal value(URL): 60MPa	
		L706S	Nominal value(URL): 70MPa	
	L107S	Nominal value(URL): 100MPa		
	Sensor seal	S	O-ring, FKM ( high temperature condition)	
		F	Stainless steel welding seal	
C		O-ring, neoprene ( low temperature condition)		
Electrical connetion	Separator	-	Detailed specifications as following	
	Electrical connetion	F1	Stainless steel termimal, aviation plug M12*1 (4 pin) (H2), IP67,vertical mounting	*
		F2	Stainless steel termimal, aviation plug M12*1 (4 pin) (H2), IP67,horizontal mounting	*
Output	Separator	-	Detailed specifications as following	
	Output signal	F	4-20mA two wire, power supply: 10-30VDC	
		H	4-20mA+HART two wire, power supply: 16.5-55VDC	*
	Display	A	Without LCD display	
		C	LCD display	*

## Ordering information chapter

Process connection	Separator	-	Detailed specifications as following		
	Material	4	SUS304	*	
		6	SUS316		
	Specification	M01	M20*1.5 (M), Φ3 pressure lead hole, GB/T193-2003, ISO261		*
		G01	G1/2 (M), Φ3 pressure lead hole, GB/T7307, ISO228, DIN16288, BS2779		*
		G02	G1/4(M), Φ3 pressure lead hole, EN837		
		G08A	G1/4(M), Φ3 pressure lead hole, GB/T7307, ISO228, DIN16288, BS2779, seal refers to DIN3852-E (back-end seal), maximum measuring range:60 MPa		
		R01	1/2 -14NPT(M), Φ3 pressure lead hole, GB/T12716, ANSI/ASME B1.20.1		*
		R02	1/4 -18NPT(M), Φ3 pressure lead hole, GB/T12716, ANSI/ASME B1.20.1		
		R03	1/2 -14NPT(F), Φ3 pressure lead hole, GB/T12716, ANSI/ASME B1.20.1		
R04	1/4 -18NPT(F), Φ3 pressure lead hole, GB/T12716, ANSI/ASME B1.20.1				
Additional options	Separator	-	Detailed specifications as following		
Process connection mounting accessory	/N1	/N1	Heat exchange connector, M20*1.5 (F) change to M20*1.5(M), SUS304	*	
		/N2	Heat exchange connector, M20*1.5 (F) change to M20*1.5(M), SUS304	*	
Process connection accessory	/Z1	/Z1	Welding connector, M20*1.5(F), SUS304	*	
		/Z2	Welding connector, G1/2(F), SUS304	*	
Electrical connection accessory	/J1	/J1	Aviation female plug (straighter) with 2m cable, 4 pin, M12*1, IP67	*	
		/J2	Aviation female plug (elbow) with 2m cable, 4 pin, M12*1, IP67		
Display mode	/D1	/D1	According to your requirements		
Calibration report	/Q1	/Q1	Calibration report provided by our company		
Approvals (multiple)	/L1	/L1	Intrinsic safety certificate, ExiaIICT4, NEPSI	*	
		/L3	CE certificate	*	

**Factory settings and parameters**

Item	Menu mark	Factory setting value
Tag position	None	0(No specific settings)
Analog output type	mA	Liner
Display mode	DISP	PV
Alarm signal	ALARM	No

Item	Menu mark	Factory setting value
Damping value	DAMP	0(No specific settings)
4mA Lower range value	LRV	According to the order value
20mA Upper range value	URV	According to the order value
Process unit	U	According to the order

**Approvals**

**Factory certificate**

Certification organization	Intertek
Quality management system	ISO9001-2008
Scope of certification	Design and production of pressure transmitter
Registration number	110804039

**CE**

Licence scope	PRESSURE TRANSMITTER
Standard	EN61000-6-2 : 2005
	EN61000-6-4 : 2007
Registered number	AC/0100708



scan & follow LEEG wechat



check website for more info