

Product information

Brief introduction

Dual flush diaphragm

Standard extended diaphragm

SMP858 monosilicon pressure transmitter is a high performance pressure transmitter with international leading technology meticulously designed by LEEG instrument, using the world's most advanced monosilicon pressure sensor technology and patent encapsulation technology. Monosilicon pressure sensor locates on the top of the metal body and stay away from the medium interface to realizes mechanical isolation and thermal isolation. Glass sintering sensor wire realizes high strength electrical insulation of metal base and improves the capability of flexibility of electronic circuit and transient voltage resistance protection. All these original encapsulation technologies enable SMP858 to easily cope with extreme chemical occasion and mechanical load, and own strong resistance to EMI, sufficient to respond to the most rigorous industrial environment applications, which are the genuine invisible instruments.

Main parameters

Pressure types	Differential pressure
Measuring range	10kPa-1MPa, please refer to the ordering information chapter
Output signal	4-20mA, 4-20mA+HART, others
Reference accuracy	±0.1% URL, optional ±0.075% URL

Measuring medium

Viscous, paste-like, adhesive, crystallising, particulatescontaining and contaminated media

Field of application

Pressure, level, differential pressure, density, interface, flow

Approvals



Technical specifications

Measuring range and limit

Nominal value	Smallest calibratable span	Lower range limit (LRL)	Upper range limit (URL)	Static pressure limit*	High pressure side overload limit*	Low pressure side overload limit*
40kPa	10kPa	-40kPa	40kPa	10MPa	10MPa	10MPa
250kPa	12.5kPa	-250kPa	250kPa	10MPa	10MPa	500kPa
1MPa	50kPa	-500kPa	1MPa	10MPa	10MPa	500kPa

Adjust requirements: lower range value (LRV) and upper range value (URV) can be adjusted within the scope of the upper and lower range limit, when  $|URV| \geq |LRV|$ , needs  $|URV| \geq$  smallest calibratable span; when  $|URV| \leq |LRV|$ , needs  $|LRV| \geq$  smallest calibratable span

\*Limit value of overpressure: depends on the pressure value of the parts with lowest pressure capacity

Standard specifications and reference conditions

Test standard: GB/T28474 / IEC60770; Zero based-calibration span, silicon oil filling, 316L stainless steel isolated diaphragm, 4-20mA analog output.

Static pressure effects

Effect on zero	$\pm 0.15TD \% URL/4MPa$
Effect on full scale	$\pm 0.2\% URL/4MPa$

Performance specifications

The overall performance including but not limited to **【Reference accuracy】**, **【Environment temperature effects】**, **【Static pressure effects】** and other comprehensive error

Typical accuracy:  $\pm 0.1\% URL$

Stability:  $\pm 0.2\% URL/ 5 \text{ years}$

Power supply effects

When power supply voltage is within 10.5/16.5-55VDC, zero and span change should not more than  $\pm 0.005\% URL/V$

Mounting position effects

Install error less than 400Pa, which can be corrected by PV=0 reset.

Reference accuracy

Including linearity(BFSL), hysteresis and repeatability. calibration temperature:  $20 \text{ }^\circ\text{C} \pm 5 \text{ }^\circ\text{C}$

Linear output accuracy	TD $\leq 10$ (note 1)	$\pm 0.1\% URL$	Nominal value: 40kPa, 250kPa 1MPa
	10<TD $\leq 20$	$\pm 0.01TD\% URL$	

Square root output accuracy is 1.5 times linear output accuracy

Note 1: TD is Turn down when  $|URV| \geq |LRV|$ ,  $TD=URL/|URV|$  when  $|URV| \leq |LRV|$ ,  $TD=URL/|LRV|$

Vibration effects

According to GB/T1827.3/IEC61298-3,  $< 0.1\% URL$

Output signal

Two wire 4-20 mA output with digital communications, linear or square root output programmable, HART protocol is superimposed on the 4-20mA signal.

Ambient temperature effects

Within the range - 20-80 $^\circ\text{C}$ total impact	$\pm(0.1+0.1TD)\% URL$
--	------------------------

Disclaimer: all the data used in the product description is not legally binding. Relevant technical details may be changed due to further improve

Technical specifications

Damping time

Total damping time constant: equal to the sum of damping time of amplifier and sensor capsule
Damping time of amplifier : 0-100S adjustable
Damping time of sensor capsule (isolated diaphragm and silicon oil filling )≤0.2S
Startup after power off: ≤6S
Normal services after data recovery : ≤31S

Weight

Net weight: about 6.35kg (Tri-Clamp process connection , without mounting brackets)
---

Environment condition

Items	Operational condition
Working temperature	-40-85°C, LCD display unit: -20-70°C
Storage temperature	-40-110°C, LCD display unit: -40-85°C
Media temperature	With silicon oil: -40-120°C With Neobee M-20: -10-180°C
Working humidity	5-100%RH@40°C
Protection class	IP67
Dangerous condition	ExdIICT6(GYB16.1253X)* ExialICT4(GYB16.1965X)*
*Please consult engineers for details	

Power supply

Item	Operating conditions
Standard/flame proof	10.5-55VDC
HART protocol	16.5-55VDC, communication load resistance 250Ω
Load resistance	0-2119Ω for operation, 250-600Ω for HART protocol
Transmission distance	<1000 meters
Power consumption	≤500mW@24VDC, 20.8mA

Power supply and load requirements

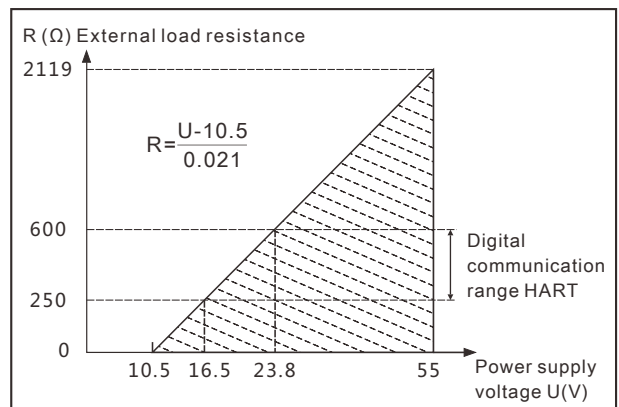

EMC environment

NO.	Test items	Basic standards	Test conditions	Performance level
1	Radiated interference	GB/T 9254/CISPR22	30MHz-1000MHz	OK
2	Conducted interference (DC power port)	GB/T 9254/CISPR22	0.15MHz-30MHz	OK
3	Electrostatic discharge immunity test (ESD)	GB/T 17626.2/IEC61000-4-2	4kV(Contact ),8kV(Air)	B(Note2)
4	Immunity to radio frequency EM-fields	GB/T 17626.3/IEC61000-4-3	10V/m(80MHz-1GHz)	A(Note1)
5	Power frequency magnetic field Immunity test	GB/T 17626.8/IEC61000-4-8	30A/m	A(Note1)
6	Electrical fast transient / Burst Immunity Test	GB/T 17626.4/IEC61000-4-4	2kV(5/50ns,100kHz)	B(Note2)
7	Surge immunity requirements	GB/T 17626.5/IEC61000-4-5	1kV(Line to line) 2kV(Line to ground) (1.2us/50us)	B(Note2)
8	Immunity to conducted disturbances induced by radio frequency fields	GB/T 17626.6/IEC61000-4-6	3V(150kHz-80MHz)	A(Note1)

(Note 1)Performance level A: The performance within the limits of normal technical specifications.

(Note 2)Performance level B: Temporary reduction or loss of functionality or performance, it can restore itself. The actual operating conditions, storage and data will not be changed.

Disclaimer: all the data used in the product description is not legally binding. Relevant technical details may be changed due to further improve

Menu function

Specific menu

Transmission module type

Output signal	Local control	Remote control
4-20mA+HART	LCD/3 buttons on body	HART
4-20mA	LCD/3 buttons on body	-

LCD display unit

Display mode	Details
PV	Process variable shows on main screen, percentage and progress bar shows on secondary screen
mA	Current shows on main screen, percentage and progress bar shows on secondary screen
%	Percentage shows on main screen, percentage and progress bar shows on secondary screen

Unit

Unit	Definition
kPa	Kilopascal
MPa	Megapascals
bar	Bar
psi	Pounds per square inch
mmHg	Millimetre(s) of mercury@0°C
mmH2O	Millimeter of water@4°C
mH2O	Meter of water@4°C
inH2O	Inches of water@4°C
ftH2O	Feet of water@4°C
inHg	Inches of mercury@0°C
mHg	Meter mercury column@0°C
TORR	Torr
mbar	Millibar
g/cm2	Gram per square centimeter
kg/cm2	Kilogram per square centimeter
Pa	PA
ATM	Standard atmospheric pressure
mm	Millimeter(Note 1)
m	Meter(Note 1)

Note 1: length unit need mark medium density

Measuring menu set

Mark	State
URV	Upper range value, 20mA
LRV	Lower range value, 4mA

Damping time

Units	Setting range
S	0-100

Analog output type

Parameters	Output type
mA LINER	Linearity
mA $\sqrt{\quad}$	Square root

Alarm signal

Parameters	Alarm signal
ALARM NO	None
ALARM H	20.8mA
ALARM L	3.8mA

Fix output

Parameters	Fix output value
FIX/C NO	None
3.8000	3.8000mA
4.0000	4.0000mA
8.0000	8.0000mA
12.000	12.000mA
16.000	16.000mA
20.000	20.000mA
20.800	20.800mA

Quick menu

Parameter	Instruction
PV=0	Set current output to zero value, used to correct the error caused by static pressure and installation.
Zero adjustment	4mA re-range with pressure
Span adjustment	20mA re-range with pressure
Restore factory setting	Restore backup data when error

Disclaimer: all the data used in the product description is not legally binding. Relevant technical details may be changed due to further improve

Product selection instruction

Sensor type

Code	Nominal value	Description
S403D	40kPa	Range -40kPa-40kPa, smallest calibratable span 10kPa
S254D	250kPa	Range -250kPa-250kPa, smallest calibratable span 12.5kPa
S105D	1MPa	Range -500kPa-1000kPa, smallest calibratable span 50kPa

Code	Position	Instruction
S	Sensor seal	O-ring, FKM, process temperature: -20~200°C

Seal(S)

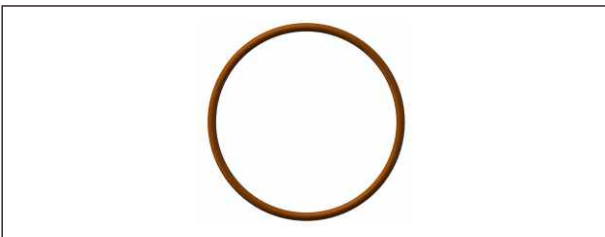

Electrical connection select instruction

Code	Item	Description
T1	Electrical connection	Aluminum-alloy terminal, 2 cable entry M20*1.5(F), red body, white cover
R1	Cable entry protector	Waterproof connector M20X1.5 one side, blind plug another side, PVC material, 6-8mm diameter cable only, IP67
R2		Flame proof, 1/2 NPT(F) one side, blind plug another side, stainless steel material, 6-8mm diameter cable only, IP67
R3		Flame proof, M20X1.5(F) one side, blind plug another side, stainless steel material, 6-8mm diameter cable only, IP67

Housing (T1)

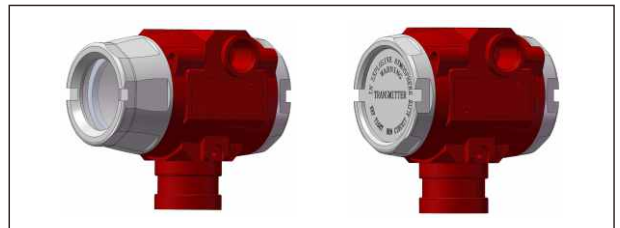

Standard cable entry protective adaptor(R1)

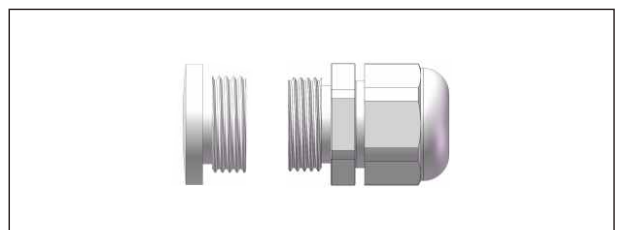

Flame proof cable entry protective adaptor(R2/R3)

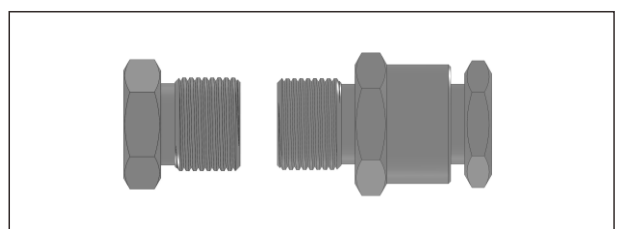

Disclaimer: all the data used in the product description is not legally binding. Relevant technical details may be changed due to further improve

Product selection instruction

Transmission module

Code	Items	Description
F	Output signal	4-20mA two wire, power supply: 10.5-55VDC
H		4-20mA+HART two wire, power supply: 16.5-55VDC
A	Display	Without display
C		With LCD display

Display module(C)



Terminals

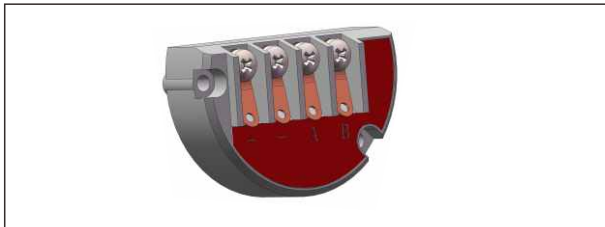

Process connection adaptor selection instruction

Code	Item	Description
A1	Process connection adaptor	Adaptor, M20*1.5(M) with pressure-leading tubeΦ14*2*30 SUS304
A2		Adaptor, 1/2-14NPT(F), SUS304

Adaptor/ M20\*1.5(M)/ with pressure-leading tube(A1)

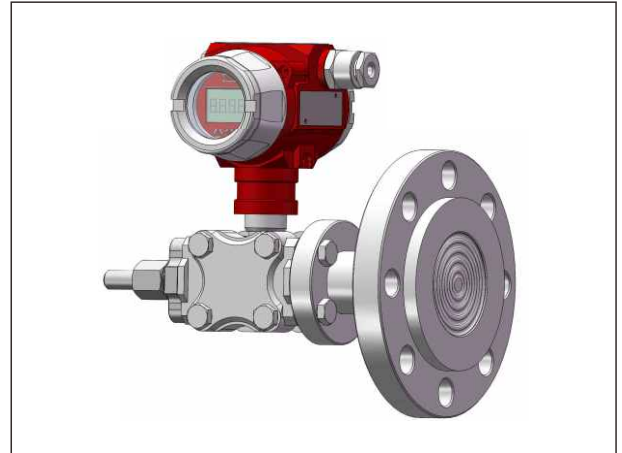

Adaptor/ 1/2-14NPT(F) (A2)

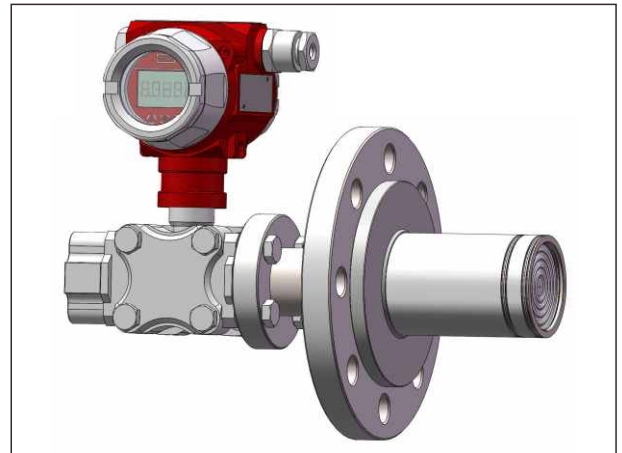

## Product selection instruction

### Process connection select instruction

Connection position	/HL	High-pressure side fixed connection, low-pressure side 1/4NPT(F) ANSI/ASME B1.20.1,
	/H	High-pressure side and low-pressure side both are diaphragm connection
Connection type	G	Fixed mounting
Isolated filling fluid	S	Silicon oil, process temperature: -45-205°C
	H	High-temperature silicon oil, process temperature: 0-315°C
	F	Hygienic fluid, Neobee M-20, process temperature: -10-180°C
Wetted parts material	4	SUS304
	6	SUS316
Diaphragm material	S	SUS316L
	H	Hastelloy C
Flange specifications	H01	HG/T 20592-2009, DN50PN10 raised face flange(max measuring range 4MPa)
	H05	HG/T 20592-2009, DN80PN10 raised face flange(max measuring range 1MPa)
	H06	HG/T 20592-2009, DN100PN10 raised face flange(max measuring range 1MPa)
Insert tube diameter	D00	None
	D01	Diameter:66mm, length:50mm
	D02	Diameter:66mm, length:100mm
	D03	Diameter:66mm, length:150mm
Connection position	/L	Low-pressure side connection
Connection type	C	Capillary transmission
Capillary type	M2	Armoured SUS304, outer diameter 3.5mm
Capillary length	XX	XX value range: 00-10, samples: 02=2 meters; 10=10meters
Isolated filling fluid	S	Silicon oil, process temperature: -45-205°C
	H	High-temperature silicon oil, process temperature: 0-315°C
	F	Hygienic fluid, NeobeeM-20, process temperature: -10-180°C
Wetted parts material	4	SUS304
	6	SUS316
Diaphragm material	S	SUS316L
	H	Hastelloy C
Flange specifications	H01	HG/T 20592-2009, DN50PN10 raised face flange(max measuring range 4MPa)
	H05	HG/T 20592-2009, DN80PN10 raised face flange(max measuring range 1MPa)
	H06	HG/T 20592-2009, DN100PN10 raised face flange(max measuring range 1MPa)
Insert tube diameter	D00	None
	D01	Diameter:66mm, length:50mm
	D02	Diameter:66mm, length:100mm
	D03	Diameter:66mm, length:150mm

Product drawing and dimension

Standard flush diaphragm drawing and dimension with display ( C ) and adaptor(A1) ( unit:mm)

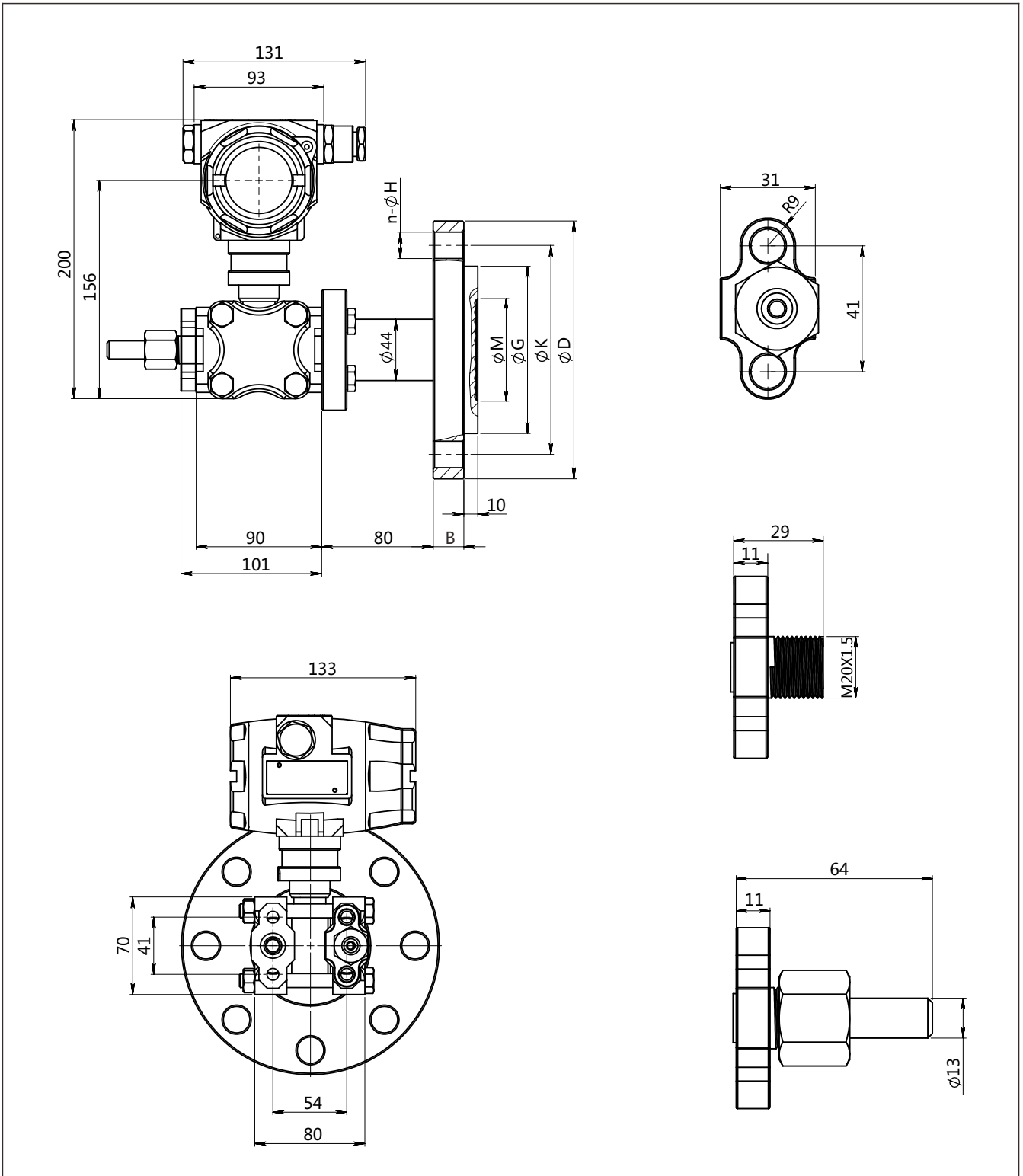

Disclaimer: all the data used in the product description is not legally binding. Relevant technical details may be changed due to further improve



Product drawing and dimension

Standard extended diaphragm with display(C) and adaptor(A2) (unit: mm)

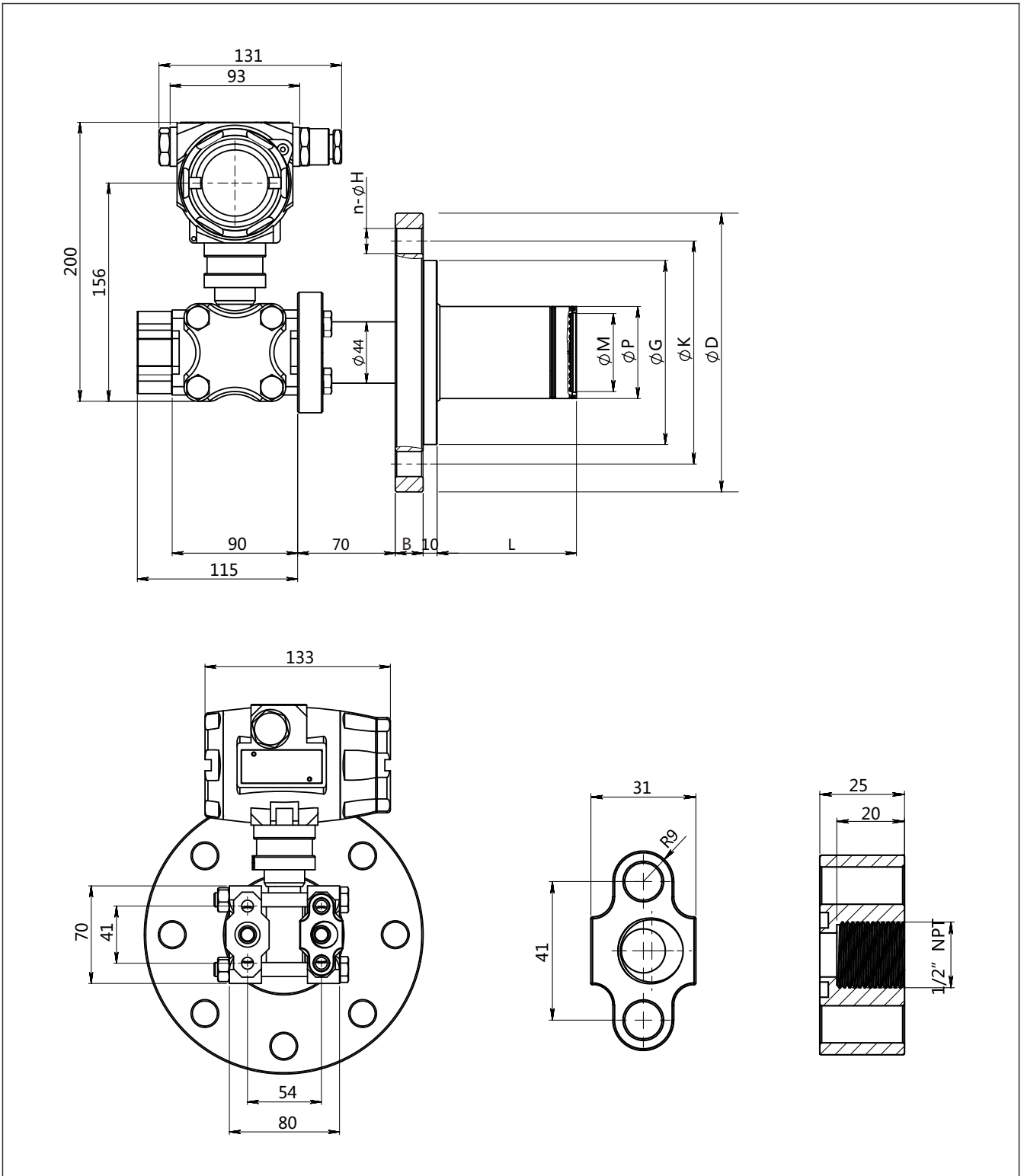

Disclaimer: all the data used in the product description is not legally binding. Relevant technical details may be changed due to further improve

Product drawing and dimension

Standard flush diaphragm drawing and dimension without display(A) (unit: mm)

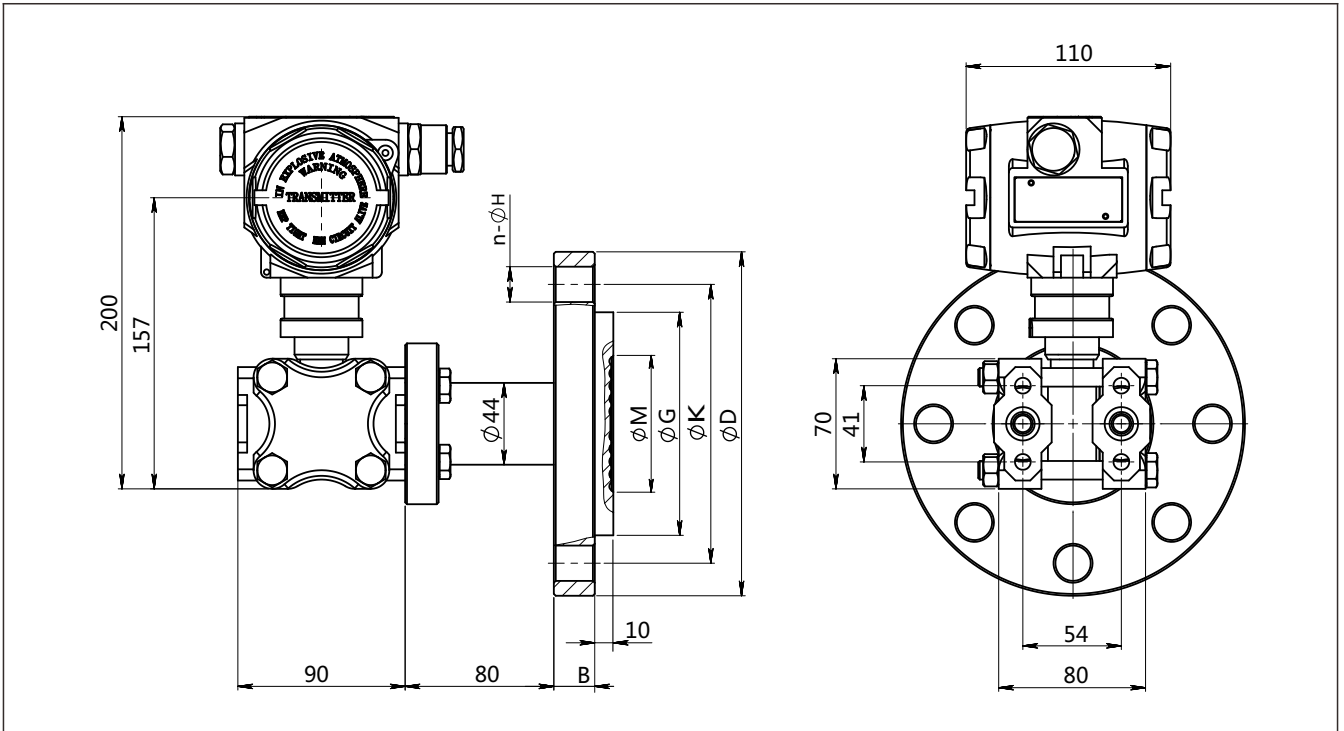

Standard extended diaphragm without display(A) (unit:mm)

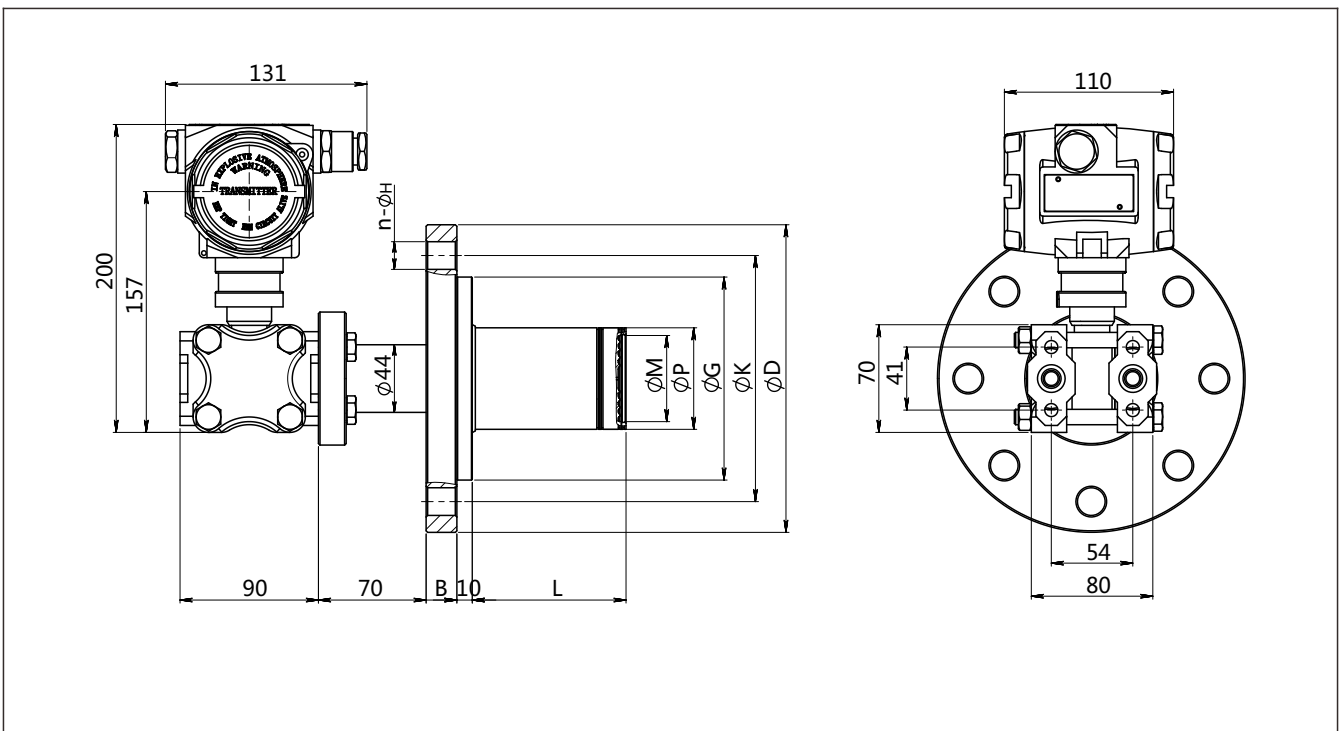

Disclaimer: all the data used in the product description is not legally binding. Relevant technical details may be changed due to further improve

Product drawing and dimension

Dual flush diaphragm drawing and dimension with display(C) ( unit: mm)

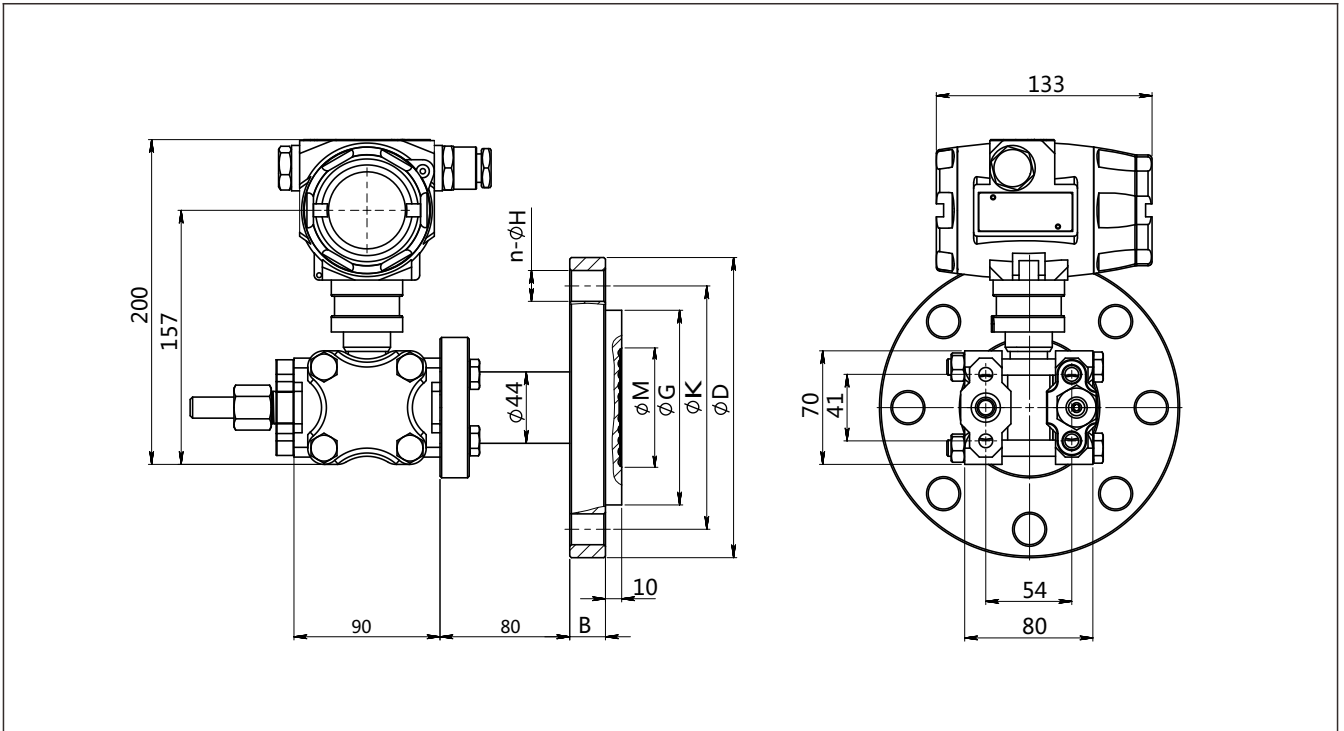

Dual extended diaphragm drawing and dimension with display(C) ( unit: mm)

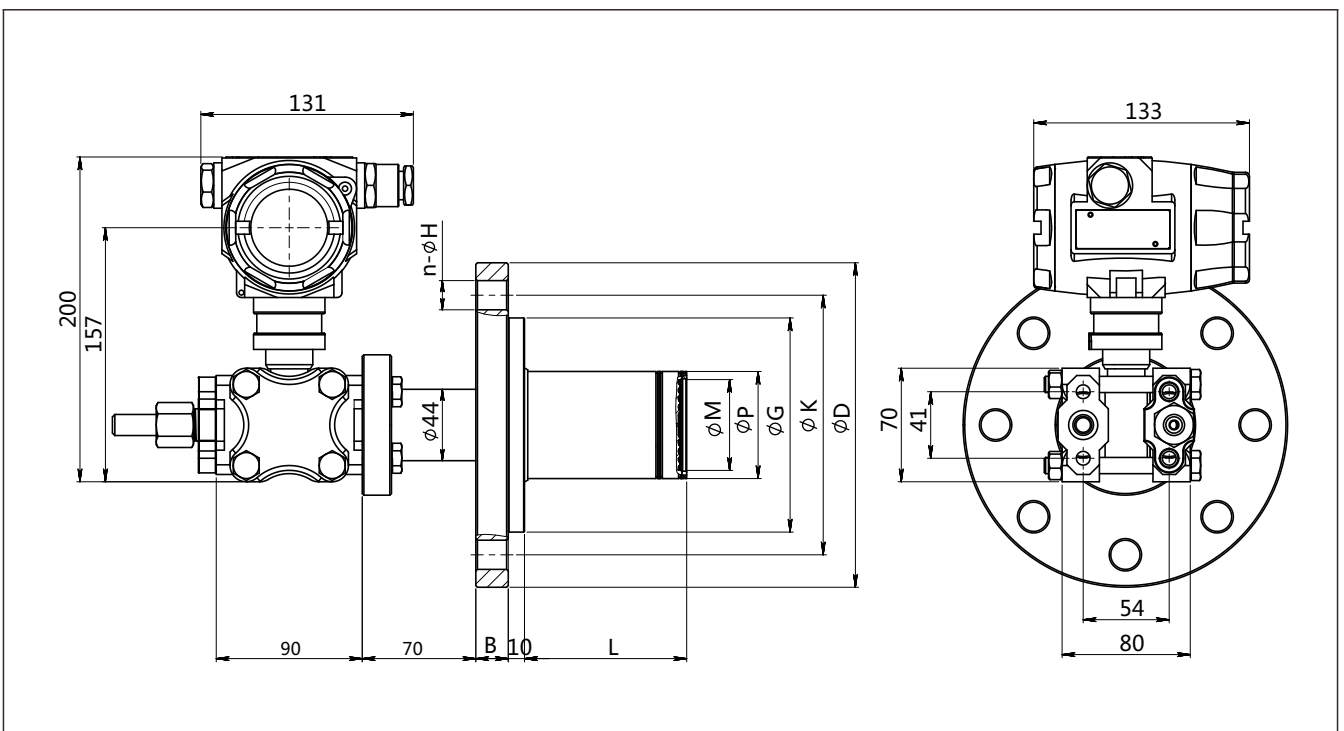

Disclaimer: all the data used in the product description is not legally binding. Relevant technical details may be changed due to further improve

Product drawing and dimension

Dual flush diaphragm drawing and dimension without display(A) ( unit: mm)

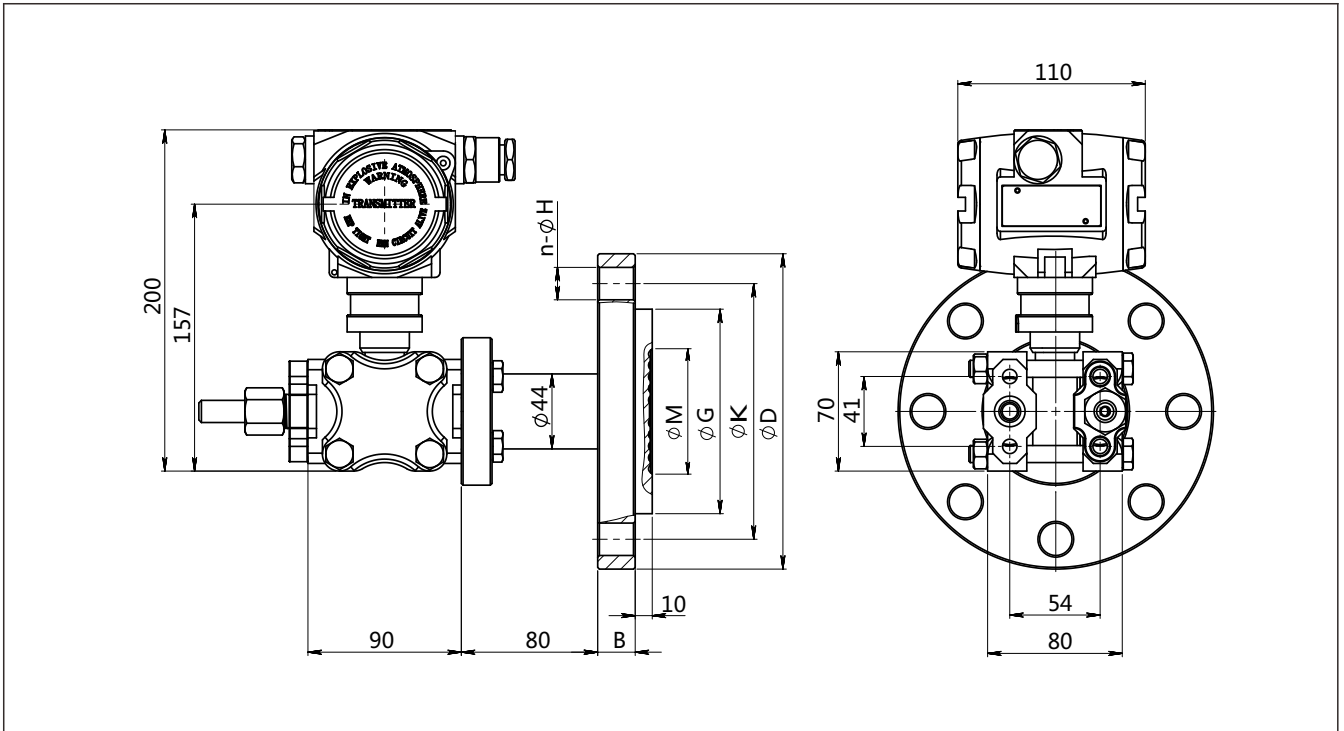

Dual extended diaphragm drawing and dimension without display(A) ( unit: mm)

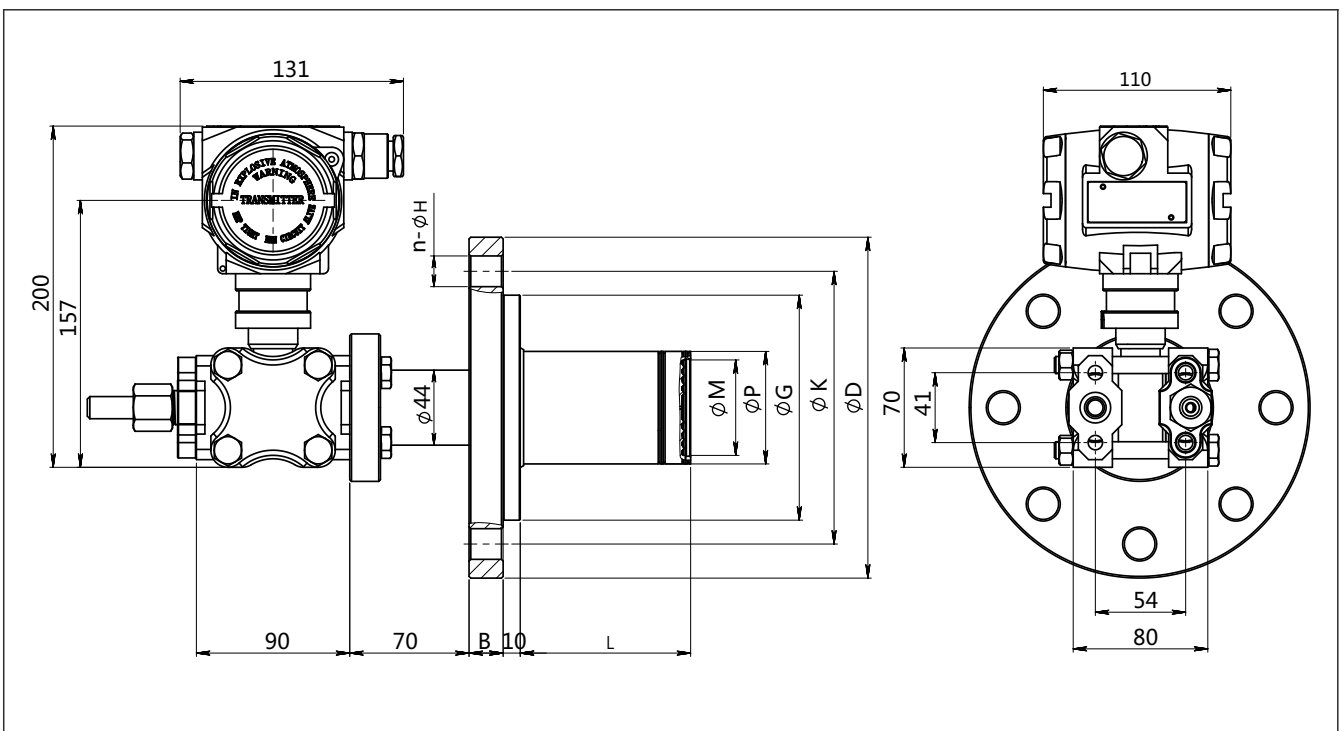

Disclaimer: all the data used in the product description is not legally binding. Relevant technical details may be changed due to further improve

Product drawing and dimension

Process connection (D01-D03)(unit: mm)

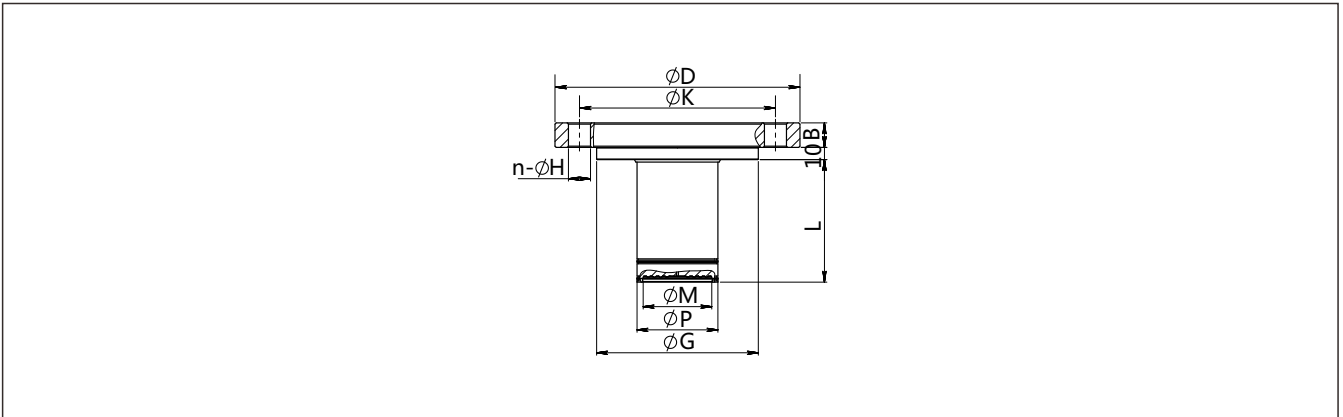

Standard	Specification	Outer diameter(ΦD)	Thickness(B)	Raised face diameter(ΦG)	
HG/T20592-2009	DN80PN10	200	20	138	
HG/T20592-2009	DN80PN10	200	20	138	
HG/T20592-2009	DN80PN10	200	20	138	
Hole circumference(ΦK)	Number(n)	Hole diameter(ΦH)	Insert tube diameter(ΦP)	Insert tube length(L)	Corrugation size(ΦM)
160	8	18	66	50	42
160	8	18	66	100	42
160	8	18	66	150	42

Process connection (H01、H05、H06) (unit: mm)

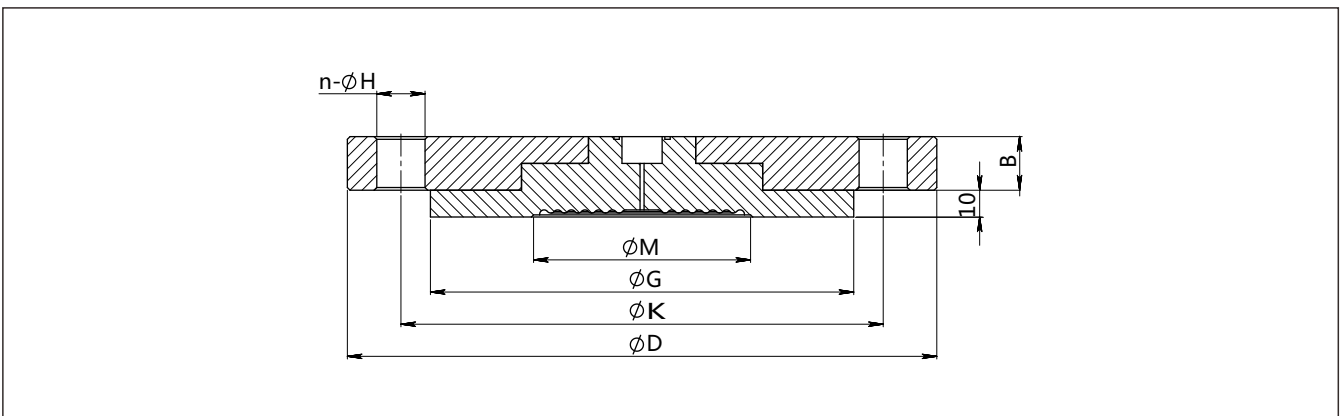

Standard	Specification	Outer diameter(ΦD)	Thickness(B)	Hole circumference(ΦK)
HG/T20592-2009	DN50PN10	165	19	125
HG/T20592-2009	DN80PN10	200	20	160
HG/T20592-2009	DN100PN10	200	20	160
Raised face diameter(ΦG)	Hole diameter(ΦH)	Number(n)	Corrugation size(ΦM)	
102	18	4	56	
138	18	8	71	
158	18	8	71	

Disclaimer: all the data used in the product description is not legally binding. Relevant technical details may be changed due to further improve

**Ordering information chapter**

Item	Parameters	Code	Instruction	(*) Fast delivery available
	Model	SMP858-DST	Monosilicon differential pressure transmitter	
Sensor	Separator	-	Detailed specifications as following	
	Pressure range code	S403D	Nominal value(URL): 40kPa	*
		S254D	Nominal value(URL): 250kPa	*
		S105D	Nominal value(URL): 1MPa	*
	Sensor seal	F	Stainless steel welding seal	*
Electrical connection	Separator	-	Detailed specifications as following	
	Electrical connection	T1	Aluminum-alloy terminal,2 cable entry M20*1.5(F), red body, white cover	*
	Cable entry protector	R1	Waterproof connector M20X1.5 one side , blind plug another side, PVC material,6-8mm diameter cable only,IP67	*
		R2	Flame proof, 1/2 NPT(F) one side, blind plug another side, stainless steel material, 6-8mm diameter cable only, IP67	
		R3	Flame proof, M20X1.5(F) one side, blind plug another side, stainless steel material, 6-8mm diameter cable only,IP67	*
Output	Separator	-	Detailed specifications as following	
	Output signal	F	4-20mA two wire, power supply: 10.5-55VDC	*
		H	4-20mA+HART two wire, power supply: 16.5-55VDC	*
	Display	A	Without LCD display	
		C	LCD display	*
Process connection	Separator	-	Detailed specifications as following	
Process connection (High-pressure side)	Connection position	HL	High-pressure side fixed connection, low-pressure side 1/4NPT(F) ANSI/ASME B1.20.1	*
		/H	High-pressure side and low-pressure side both are diaphragm connection	
	Connection type	G	Fixed mounting	*
	Isolated filling fluid	S	Silicon oil, process temperature: -45-205°C	*
		H	High-temperature silicon oil, process temperature: 0-315°C	
		F	Hygienic fluid, Neobee M-20, process temperature: -10-180°C	*
	Wetted parts material	4	SUS304	*
		6	SUS316	
	Diaphragm material	S	SUS316L	*
		H	Hastelloy C	
	Flange specifications	H01	HG/T 20592-2009, DN50PN10 raised face flange(max measuring range 4MPa)	*
		H05	HG/T 20592-2009, DN80PN10 raised face flange(max measuring range 1MPa)	*
		H06	HG/T 20592-2009, DN100PN10 raised face flange(max measuring range 1MPa)	*

Disclaimer: all the data used in the product description is not legally binding. Relevant technical details may be changed due to further improve

Ordering information chapter

	Insert tube diameter	D00	None	
		D01	Diameter:66mm, length:50mm	*
		D02	Diameter:66mm, length:100mm	
		D03	Diameter:66mm, length:150mm	
Process connection (Low-pressure side)(While low pressure side is diaphragm connection)	Connection position	/L	Low-pressure side connection	
	Connection type	C	Capillary transmission	
	Capillary type	M2	Armoured SUS304, outer diameter 3.5mm	
	Capillary length	XX	XX value range: 00-10,samples: 02=2 meters; 10=10meters	
	Isolated filling fluid	S	Silicon oil, process temperature: -45-205°C	*
		H	High-temperature silicon oil, process temperature: 0-315°C	
		F	Hygienic fluid, Neobee M-20, process temperature: -10-180°C	*
	Wetted parts material	4	SUS304	*
		6	SUS316	
	Diaphragm material	S	SUS316L	*
		H	Hastelloy C	
	Flange specifications	H01	HG/T 20592-2009, DN50PN10raised face flange(max measuring range 4MPa)	*
		H05	HG/T 20592-2009, DN80PN10 raised face flange(max measuring range 1MPa)	*
		H06	HG/T 20592-2009, DN100PN10 raised face flange(max measuring range 1MPa)	*
Insert tube diameter	D00	None		
	D01	Diameter:66mm, length:50mm	*	
	D02	Diameter:66mm, length:100mm		
	D03	Diameter:66mm, length:150mm		
Additional options	Separator	-	Detailed specifications as following	
	Process connection accessory	/A1	T-shaped adaptor, M20*1.5(M) and pressure-leading tubeΦ14*2*30, SUS304(low-pressure side)	*
		/A2	U-shaped adaptor, 1/2-14NPT(F), SUS304(low-pressure side)	*
	Display mode	/D1	According to your requirement	
	Calibration report	/Q1	Calibration report provided by our company	*
		/Q2	Calibration report provided by chinese authorised third party	
		/Q3	Static pressure report ( Differential pressure only)	
	Approvals (multiple)	/E1	Flame proof certificate, ExdIICT6, NEPSI	*
		/I1	Intrinsic safety certificate, ExialICT4, NEPSI	*
		/F3	CE certificate	*
	Wetted parts treatment	/G1	Ungrease treatment	
/G2		Electropolishing treatment		

Disclaimer: all the data used in the product description is not legally binding. Relevant technical details may be changed due to further improve

**Factory settings and parameters**

Item	Menu mark	Factory setting value
Tag position	None	0(No specific settings)
Analog output type	mA	Liner(No specific settings)
Display mode	DISP	PV(No specific settings)
Alarm signal	ALARM	No(No specific settings)

Item	Menu mark	Factory setting value
Damping value	DAMP	0(No specific settings)
4mA Lower range value	LRV	According to the order value
20mA Upper range value	URV	According to the order value
Process unit	U	According to the order

**Approvals**

**Factory certificate**

Certification organization	Intertek
Quality management system	ISO9001-2008
Scope of certification	Design and production of pressure transmitter
Registration number	110804039

**Intrinsic safety certificate**

Certification organization name	NEPSI
Licenses range	SMP858 series pressure transmitter
Explosion-proof mark	ExiaIICT4
Ambient temperature	-40-+60°C
Medium maximum temperature	+120°C
Registration number	GYB16.1965X
Intrinsically safe parameter description	Maximum input voltage: 28VDC
	Maximum input current: 100mA
	Maximum input power: 0.7w
	Maximum internal equivalent parametersCi(uF): 0 Maximum internal equivalent parametersLi(mH): 0.01

**CE**

Certificate organization	ISET
License scope	SMP858 series pressure transmitter
Mark	CE
EMC instruction	2014/30/EU
Standard	EN61326-1: 2013
Registration number	IT051353LG161207

**Flame proof certificate**

Certification organization	NEPSI
License scope	SMP858 series pressure transmitter
Explosion-proof mark	ExdIICT6
Working environmental temperature	-25-+60°C
Maximum medium temperature	+80°C
Registration number	GYB16.1253X



scan & follow LEEG wechat



check website for more info